



ishear

GUILLLOTINE SHEAR



1950

MVD produced its first machine .

1971

The first sheet metal working machine “perforation press” was presented to the market.

1974

The production of “Heavy-duty Press Brakes and Guillotine Shears” started and MVD had the distinction of being the first Turkish manufacturer for heavy press brakes and shears.

1981

Moved to second factory and added the production of 4 roll bending machines and Expanded Metal presses in the next years. Thus, a great variety of machines were presented in sheet metal working industry.

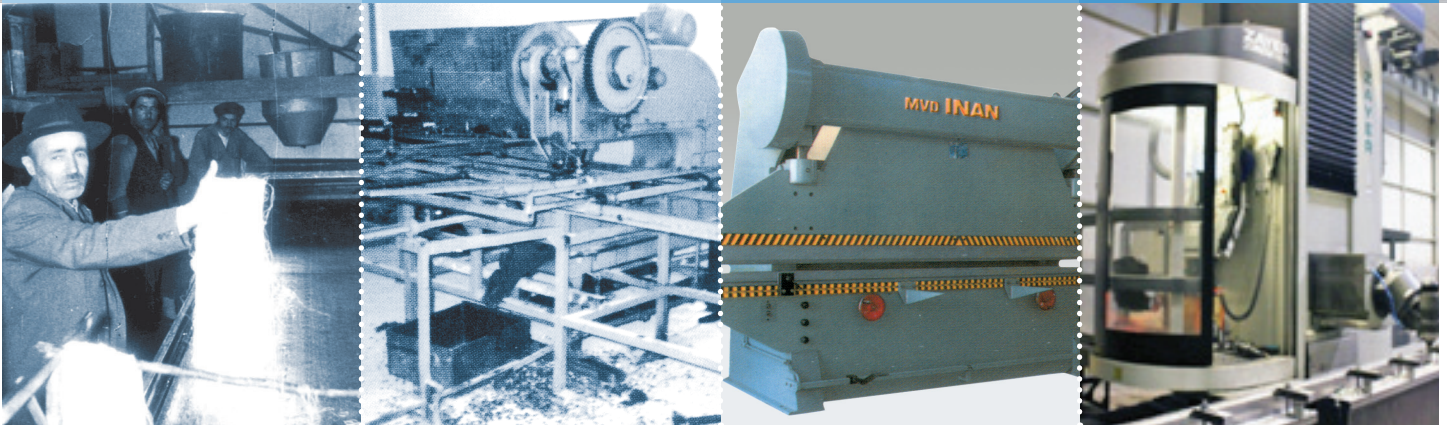



1994

MVD produced the first tandem press brake in Turkey.

2001

Finalised the CE conformity procedures and had its machines CE marked.

2003

CNC Hydraulic Turret Punch machine was presented to the market.

2011

Plasma cutting machine and Fiber Laser Cutting machines were presented to the market.

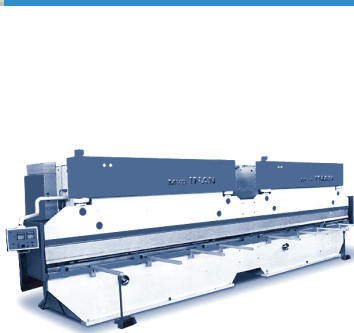





Quality High Technology

Quality and service support is accepted as principle. Designing and manufacturing are based on reliability, durability and precision.

Machines are easy to use and are built to be ready for user errors. Machines are designed and analyzed with 3-D supported computer aided programs, precisely machined in moving column CNC machining centres, equipped with world-known equipments and presented to the customers' use after quality control.





General Features

- ▶ A SERIES Guillotine Shears, suitable for cutting thin sheet material, up to thickness of 4 mm
- ▶ Machine body and upper beam is made of steel constructions, has been designed according minimum stretch and optimum resistance criteria
- ▶ Body, as the manufacture of precise CNC machining center for provide maximum cutting quality and accuracy.

iShear A Series

MECHANICAL GUILLOTINE SHEAR

Standard Equipments

- ▶ Welded one piece steel frame using rigid structural steel
- ▶ Rigid welded monoblock frame provide Maximum cutting accuracy,
- ▶ Digital NC control unit
- ▶ Automatic, Digital controlled motorized back gauge 750mm range (stroke)
- ▶ Schneider-Telemecanique electrical components, with ventilations electrical cabinet
- ▶ 4 Cutting edges blade produced from high alloy steel
- ▶ Mechanical sheet hold down system holds the sheet in place during the cutting process.
- ▶ Simple and Easy operable Blade Gap adjustment system
- ▶ Roller bearings on the table to help feeding sheets to the machine easily
- ▶ Front Support Arms with scale
- ▶ Foot pedal stand and control unit for Single or Multi cutting operations
- ▶ Rear light beams with CE conformity
- ▶ Emergency stop button
- ▶ Back side protections cover
- ▶ Shadow, illuminations cutting line
- ▶ Complete electrical switch board and control panel for 400V AC 3 Phase 50Hz

Optional Equipments

- ▶ Touch Screen CNC controller
- ▶ Pneumatic sheet support system and sheet sliding
- ▶ Adjustable Angular gauge sliding T slot (0-180 degree) on front
- ▶ Longer Front Support Arms

iShear A Series Equipments

▶ Controller



▶ Elgo P9521 NC
Standard



▶ Cybelec Touch 6
Optional



▶ Elgo P40
Optional

▶ Equipments



▶ Pneumatic Sheet Support System
Optional



▶ Adjustable Angular Gauge
Optional

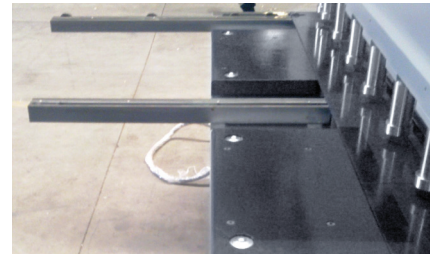

▶ Roller Bearing Top Table

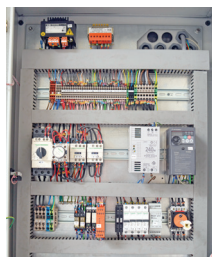

▶ Electrical Cabinet

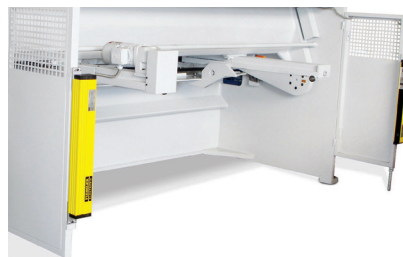

▶ Rear Protection Light Beams

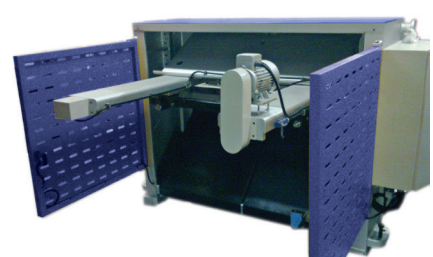

▶ Back Gauge

Technical Features

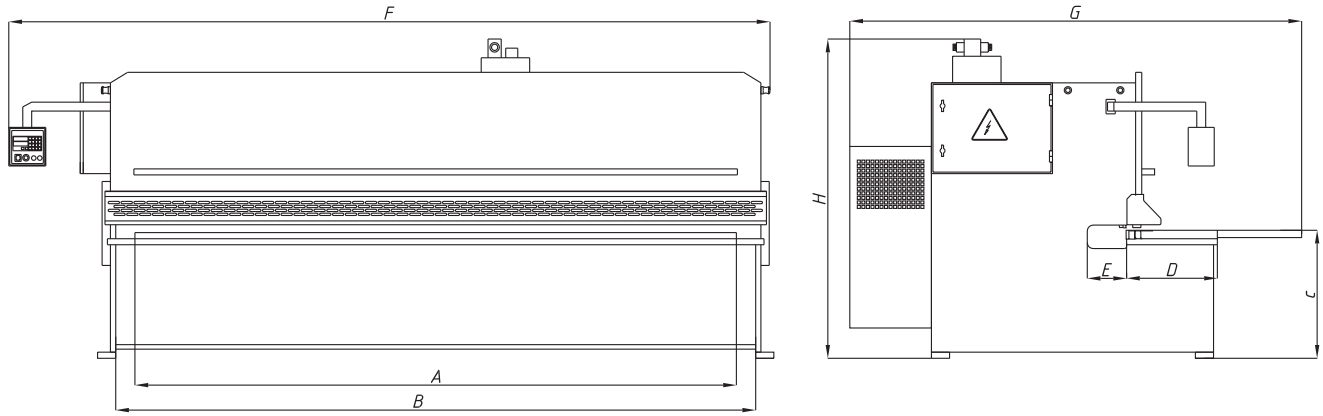

Technical Table

iShear A Series		A04-2000	A04-2600	
Cutting capacity		4	4	mm.
Cutting length	A	2100	2600	mm.
Cutting Angle		1,7	1,7	degree
Speed Stroke per Minute		42	34	1/min
Table Height	C	850	850	mm.
Machine Length	F	2500	3100	mm.
Machine Height	H	1350	1350	mm.
Machine Width	G	2250	2250	mm.
Motor Power		7,5	7,5	Kw.
Weight		2500	2900	Kg
Technical specifications are subject to change without notice				
Special capacity machines can be manufactured upon request				



HIGH SPEED CUTTING QUANTITY DOUBLE SPEED SYSTEM

iShear B Series

HEAVY-DUTY HYDRAULIC SWING BEAM SHEARS

General Features

- ▶ Special Design MVD swing beam shears provide up to 25 cutting stroke per minute .
- ▶ When cutting thin sheets, up to 50% faster cutting and efficiency gains achieved with high speed,
- ▶ precise cutting is provided for thick materials with slow speed working mode .
- ▶ Manufactured in sizes 3 meters to 6 meters and capacities 6mm to 20mm .
- ▶ Provides high cutting quality with low cutting angle design machine concepts
- ▶ Construction feature has a fixed angle of cut
- ▶ Machine can produce with automatically blade gap and stroke adjustment by CNC controller according to customer's request
- ▶ Machine body and upper beam's made of steel constructions, has been designed according minimum stretch and optimum resistance criteria
- ▶ Body, as the manufacture of precise CNC machining center for provide maximum cutting quality and accuracy.
- ▶ Body, as the manufacture of precise CNC machining center is a single operation
- ▶ Designed Heavy –Duty rigid body concept in order to prevent deflections.
- ▶ Back gauge range (stroke) 1000 mm .
- ▶ Back gauge accuracy performed with linear ball shaft, without backlash guide
- ▶ Programmable back gauge has 0,1 mm positioning tolerance and retract features .
- ▶ Automatic swing –up feature of backgauge after 1000mm to feed longer sheets easily

▶ Controller



▶ Elgo P9521 NC
Standard



▶ Cybelec Touch 6
Optional

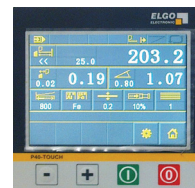

▶ Elgo P40 Touch
Optional

Standard Equipments

- ▶ NC Controller
- ▶ Easily adjustable with scale blade gap setting system for precise cutting and long life blade's
- ▶ Movable controller arm
- ▶ Roller bearings on the table to help feeding sheets to the machine easily
- ▶ Welded monoblock, heavy steel frame using rigid structural steel produced with modern manufactured methods
- ▶ Automatic, Digital controlled motorized back gauge 1000 mm range (stroke) with ball shaft and guide system.
- ▶ Programmable back gauge, with retract and swing up features for longer sheets
- ▶ Prevents scratching of the sheet with ball on the table
- ▶ Hydraulic Sheet hold down system, holds the sheet in place during the cutting process.
- ▶ Cylinders, processed as precise from solid full material and made honed.
- ▶ Pistons, processed from forged steel, hardened, grinding is done, and chrome-coated.
- ▶ Simple and Easy operations Blade Gap adjustment system
- ▶ Adjustable bottom blade holder
- ▶ Double Speed machine concept
- ▶ Stroke adjustment on the control panel for increase stroke number for short cutting efficiency
- ▶ High Quality alloy material bottom and upper blade for long life
- ▶ Bottom Blade 4 edges, Upper Blade 2 edges
- ▶ No maintenance dry ball joint system
- ▶ Hoerbiger or Bosch Rexroth low maintenance hydraulic block
- ▶ Schneider-Telemecanique electrical components, with ventilations electrical cabinet
- ▶ Foot pedal stand suitable for serial cutting operation and setting blade adjustment
- ▶ Front support arms 1000mm, with scale and flip over stops in T slot
- ▶ Back and side protection covers
- ▶ CE conformity rear light beams
- ▶ Shadow, illuminations cutting line
- ▶ Emergency stop button
- ▶ Oil tank level indicator
- ▶ Complete electrical switch board and control panel for 400V AC 3 Phase 50Hz

▶ Equipments



▶ Automatic swing –up feature of back gauge after 1000mm sheets back gauge

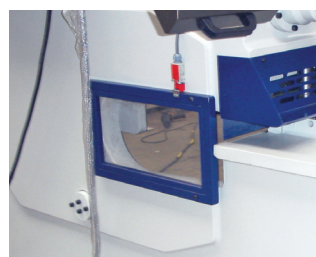

▶ Throat

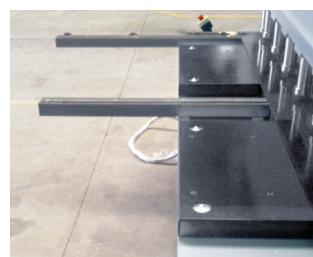

▶ Roller Bearing Top Table



▶ Blade Gap Adjustment system



▶ Front Finger Protection
Open able 1000 mm



▶ Rear Protection Light Beams

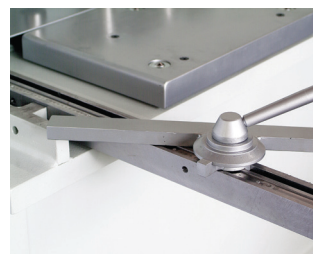

▶ Adjustable Angular Gauge
Optional



▶ Pneumatic sheet support system
Optional

Optional Equipments

- ▶ CNC AUTOSET (bladegap,stroke) OPTIONS Automatically stroke, blade gap adjustment by CNC
- ▶ Controller Cybelec Touch6 or Delem DAC310 (automatically calculations according material type and thickness, cutting lengths).
- ▶ Pneumatic sheet support system
- ▶ Cybelec Touch 6 Touch panel CNC controller
- ▶ M25 CNC Controller
- ▶ Delem DAC 310 CNC Controller
- ▶ Adjustable Angular Gauge for cutting angle parts 0-180°
- ▶ Front Finger Protection Open able 1000 mm
- ▶ Special Throat 500mm
- ▶ Front finger protection light barriers with CE conformity
- ▶ Special Blade for kind of cutting material
- ▶ Longer Front Support Arms
- ▶ 220-240V 60hz operating voltage
- ▶ 440-480V 60hz operating voltage
- ▶ 220-240V 60Hz and 440V-480V 60 Hz double operating voltage (by preliminary preparation)

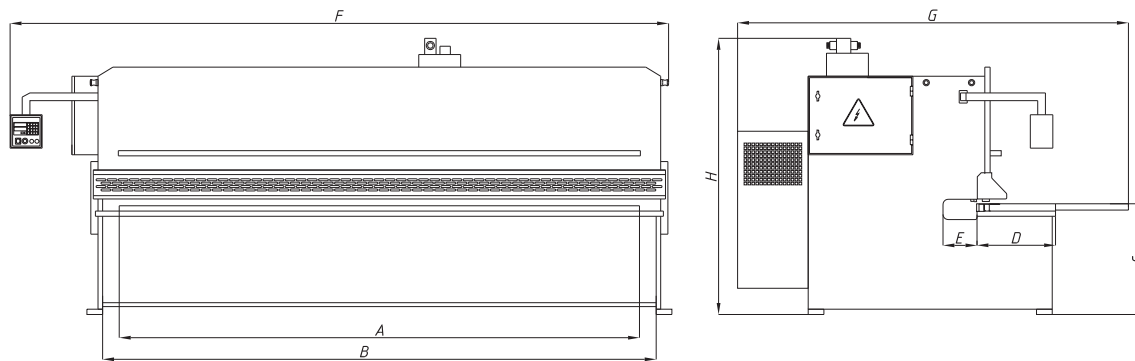

Technical Table

iShear B Series	B06-2100	B06-2600	B06-3100	B08-3100	B10-3100	B13-3100	B16-3100	B20-3100	B06-4000	B08-4000	B10-4000	B13-4000	B14-4000	B16-4000	B20-4000	B 06-6100	
Cutting capacity (450N/mm ²)	6	6	6	8	10	13	16	20	6	8	10	12	14	16	20	6	mm.
Cutting capacity (700N/mm ²)	4	4	4	5	6	8	10	13	4	5	6	8	9	10	13	4	mm.
Cutting length	A 2100	2600	3100	3100	3100	3100	3100	3100	4000	4000	4000	4000	4000	4000	4000	6150	mm.
Cutting angle	1,5	1,5	1,5	1,9	2	2,1	2,25	2,75	1,5	1,5	1,5	1,8	1,8	2,15	2,03	1	degree
Hold Down Cylinder	10	11	14	14	14	14	17	17	18	18	17	17	22	18	17	26	Unit
Speed Stroke per minute / High Speed	20/25	19/24	18/23	13/19	13/19	10/14	7/10	7/10	10/14	13/20	11/17	9/15	6/20	5/16	4/15	4/10	1/min
Distance Between Columns	B 2330	2830	3330	3340	3340	3340	3410	3410	4230	4240	4240	4315	4350	4310	4390	6440	mm.
Table Height	C 850	850	865	825	880	880	880	925	870	870	890	890	945	960	960	950	mm.
Table Width	D 500	500	500	580	600	620	585	605	600	630	635	660	625	650	710	750	mm.
Throat Depth	E 250	250	250	250	250	250	200	150	250	250	250	250	250	200	250	250	mm.
Backgauge Travel Distance Stroke	1000	1000	1000	1000	1000	1000	1000	1000	1000	1000	1000	1000	1000	1000	1000	1000	mm.
Machine Length	F 3300	3800	4300	4330	4340	4350	4450	4460	5250	5250	5260	5335	5450	5350	5450	7450	mm.
Machine Height	H 1850	1850	1935	2150	2185	2340	2400	2600	2215	2200	2380	2400	2525	2635	2865	2350	mm.
Machine Width	G 3250	3250	3250	2850	2870	2900	3115	3200	2900	2950	3040	3075	3275	3160	3170	3050	mm.
Oil tank capacity	160	160	160	230	230	230	315	350	220	220	280	370	370	370	370	350	lt.
Motor Power	10	10	10	15	22	22	30	37	10	22	22	22	30	30	37	22	Kw.
Weight	5	5,5	6	8	9,2	12,2	16,5	19	11	13,2	16,5	19	20	23	27	23	Ton

Technical specifications are subject to change without notice

Special capacity machines can be manufactured upon request



iShear C Series

CNC VARIABLE RAKE ANGE HYDRAULIC GUILLOTINE SHEARS

General Features

- ▶ Machine body and upper beam's made of steel constructions, has been designed according minimum stretch and optimum resistance criteria
- ▶ Body, as the manufacture of precise CNC machining center for provide maximum cutting quality and accuracy.
- ▶ Body, as the manufacture of precise CNC machining center is a single operation
- ▶ Designed Heavy –Duty rigid body concept in order to prevent deflections
- ▶ Back gauge range (stroke) 1000 mm.
- ▶ .Back gauge accuracy performed with linear ball shaft, without backlash guide
- ▶ Programmable back gauge has 0,1 mm positioning tolerance and retract features .
- ▶ Automatic swing –up feature of back gauge after 1000mm to feed longer sheets easily
- ▶ C series CNC Hydraulic automatic cutting angle operated shears, provides high cutting quality in the widest range of materials type and sheets thickness.
- ▶ C Series shears automatically calculate and apply; cutting angle, blade gap adjustment, stroke of the cutting length, back gauge positioning according material type and thickness with CNC controller and servo hydraulic valve.
- ▶ Cutting angle automatically adjusted according sheet thickness, this features provide high and precise cutting quality and reduced twisting or torsion effects of thin and narrow parts also .
- ▶ When cutting thin and short parts, Stroke reduced, performed number of stroke, speed increase .
- ▶ Prevent user errors, increases blade life
- ▶ Top beam precise movement provided with hardened slide ways and pulley

▶ Controller



▶ Delem DAC 360



▶ Cybelec DNC 60



▶ ESA



▶ Elgo P40 Touch



▶ Cybelec Touch 6

Standard Equipments

- ▶ CNC controller
- ▶ Easily adjustable with scale blade gap setting system for precise cutting and long life blade's
- ▶ Movable controller arm
- ▶ Roller bearings on the table to help feeding sheets to the machine easily
- ▶ Welded monoblock heavy steel frame using rigid structural steel produced with modern manufactured methods
- ▶ Automatic, CNC controlled motorized back gauge 1000 mm range (stroke) with ball shaft and guide system .
- ▶ Programmable backgauge, with retract and swing up features for longer sheets
- ▶ Prevents scratching of the sheet with ball on the table
- ▶ Pressure adjustable Hydraulic sheet holder system, protect sheet parts when cutting process
- ▶ Cylinders, processed as precise from solid full material and made honed .
- ▶ Pistons, processed from forged steel, hardened, grinding is done, and chrome-coated.
- ▶ Automatic cutting angle adjustment operation
- ▶ Automatic blade gap adjustment operation
- ▶ Automatic stroke adjustment operation
- ▶ Adjustable bottom blade holder provide high precise robust set for long life blade
- ▶ Adjustable cutting length on the control panel, increase speed number of stroke for short parts
- ▶ High Quality alloy material bottom and upper blade for long life
- ▶ Bottom Blade 4 edges, Upper Blade 4 edges
- ▶ No maintenance dry ball joint system
- ▶ Hoerbiger or Bosch Rexroth low maintenance hydraulic block
- ▶ Schneider-Telemecanique electrical components, with ventilations electrical cabinet
- ▶ Foot pedal stand suitable for serial cutting operation and setting blade adjustment
- ▶ Front support arms 1000mm, with scale and flip over stops in T slot
- ▶ Back and side protection covers
- ▶ CE conformity rear light beams
- ▶ Shadow, illuminations cutting line
- ▶ Emergency stop button
- ▶ Oil tank level indicator
- ▶ Stroke hits Counter
- ▶ Complete electrical switch board and control panel for 400V AC 3 Phase 50Hz

▶ Equipments



▶ Automatic Swing-Up Feature of Back Gauge After 1000 mm Sheets Back Gauge

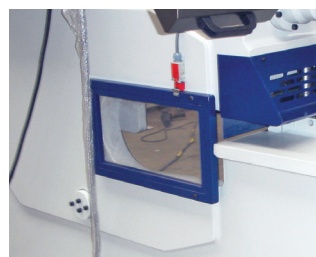

▶ Throat

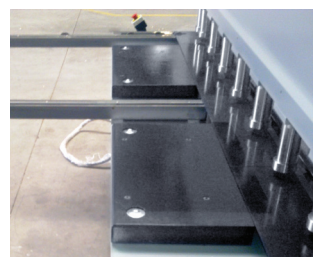

▶ Roller Bearing Top Table



▶ Automatic Blade Gap Adjustment System



▶ Front Finger Protection Open Able 1000 mm



▶ Rear Protection Light Beams



▶ Adjustable Angular Gauge
Optional



▶ Pneumatic Sheet Support System
Optional

Optional Equipments

- ▶ Pneumatic sheet support system
- ▶ Front Finger Protection Open able full length
- ▶ Adjustable Angular Gauge for cutting angle parts 0-180°
- ▶ Longer Front Support Arms
- ▶ Special Throat 500mm
- ▶ Front finger protection light barriers with CE conformity
- ▶ Special Blade for kind of cutting material
- ▶ 220-240V 60hz operating voltage
- ▶ 440-480V 60hz operating voltage
- ▶ 220-240V 60Hz and 440V-480V 60 Hz double operating voltage (by preliminary preparation)

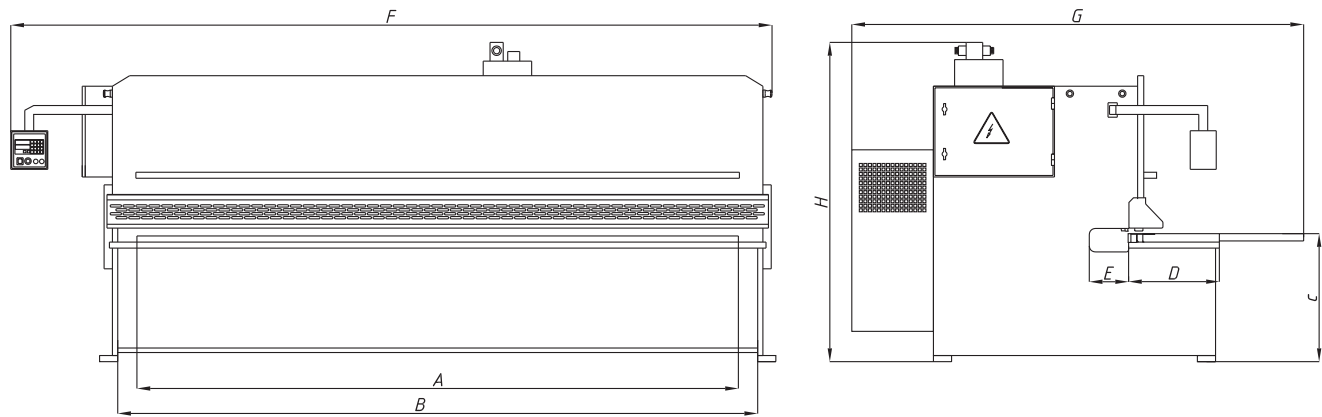

▶ Technical Table

iShear C series		C06-3100	C08-3100	C10-3100	C13-3100	C16-3100	C20-3100	C06-4000	C08-4000	C10-4000	C13-4000	C16-4000	C20-4000	C10-6000	C13-6000	C16-6000	C20-6000	
Cutting capacity (450N/mm ²)		6	8	10	13	16	20	6	8	10	13	16	20	10	13	16	20	mm.
Cutting capacity (700N/mm ²)		4	5	6	8	10	13	4	5	6	8	10	13	6	8	10	13	mm.
Cutting length	A	3100	3100	3100	3100	3100	3100	4000	4000	4000	4000	4000	4000	6150	6150	6150	6150	mm.
Cutting angle		0,5-2	0,5-2,5	0,5-3	0,5-3	0,5-3	0,5-3	0,5-2	0,5-3	0,5-3	0,5-3	0,5-3	0,5-3	0,5-3	0,5-3	0,5-3	0,5-3	degree
Hold Down Cylinder		14	14	14	14	17	17	17	17	18	18	18	18	26	26	26	26	Unit
Speed Stroke per minute / High Speed		10/15	10/15	7/15	7/15	6/15	6/15	10/14	9/13	6/13	6/13	6/12	6/12	5/12	5/12	5/9	5/7	1/min
Distance Between Columns	B	3500	3450	3600	3600	3670	3705	4460	4470	4490	4500	4580	4590	6610	6500	6650	6650	mm.
Table Height	C	775	855	880	975	995	995	860	860	945	950	1010	1025	1135	1255	1270	1285	mm.
Table Width	D	520	600	620	620	705	720	600	630	650	700	700	720	735	845	920	1100	mm.
Throat Depth	E	250	250	250	250	250	250	250	250	250	250	250	250	250	250	250	250	mm.
Backgauge Travel Distance Stroke		1000	1000	1000	1000	1000	1000	1000	1000	1000	1000	1000	1000	1000	1000	1000	1000	mm.
Machine Length	F	4500	4500	4620	4640	4730	4735	5460	5470	5520	5530	5650	5670	7650	7600	7750	7750	mm.
Machine Height	H	2010	2170	2460	2590	2730	2700	2200	2350	2600	2650	2830	2900	3000	3050	3200	3350	mm.
Machine Width	G	2625	2650	2950	3050	3055	3080	2700	2850	3075	3100	3000	3000	3200	3200	3250	3300	mm.
Oil tank capacity		140	230	230	230	315	370	230	230	280	370	370	370	300	305	430	535	lt.
Motor Power		10	15	22	22	30	37	10	15	22	22	30	37	22	22	30	37	Kw.
Weight		6	7,5	10,5	12,5	16	20	12	14	16	18	22	27	28	35	40	50	Ton

Technical specifications are subject to change without notice

Special capacity machines can be manufactured upon request

Special Applications

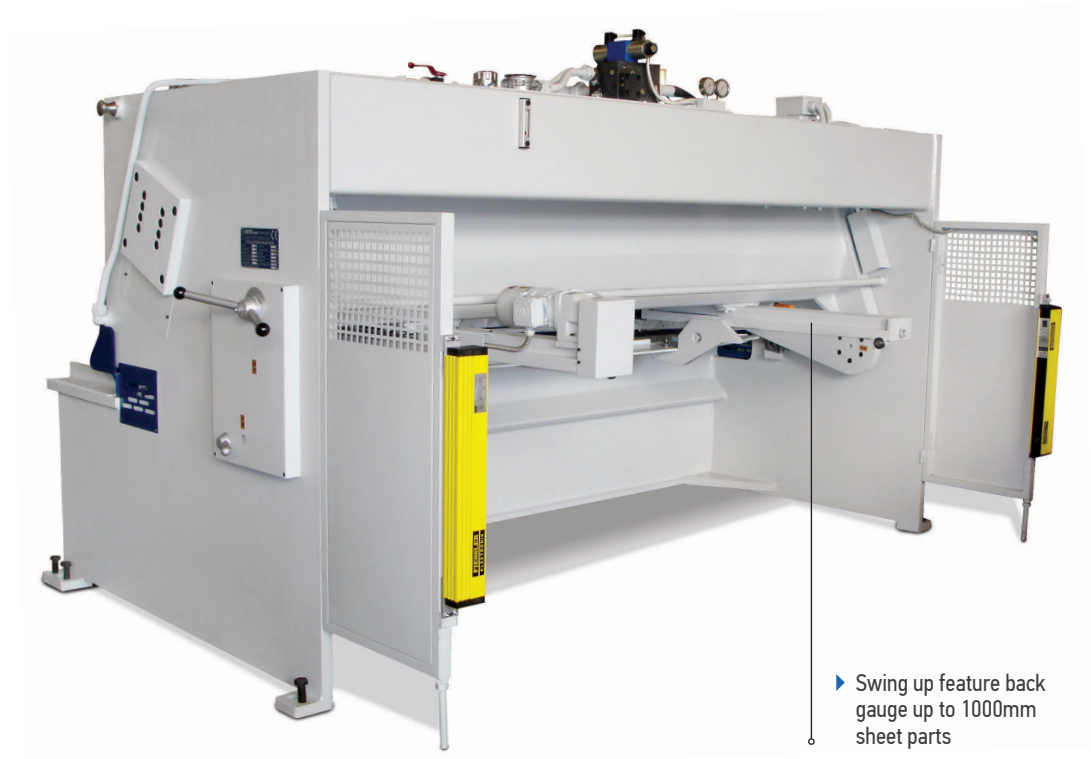
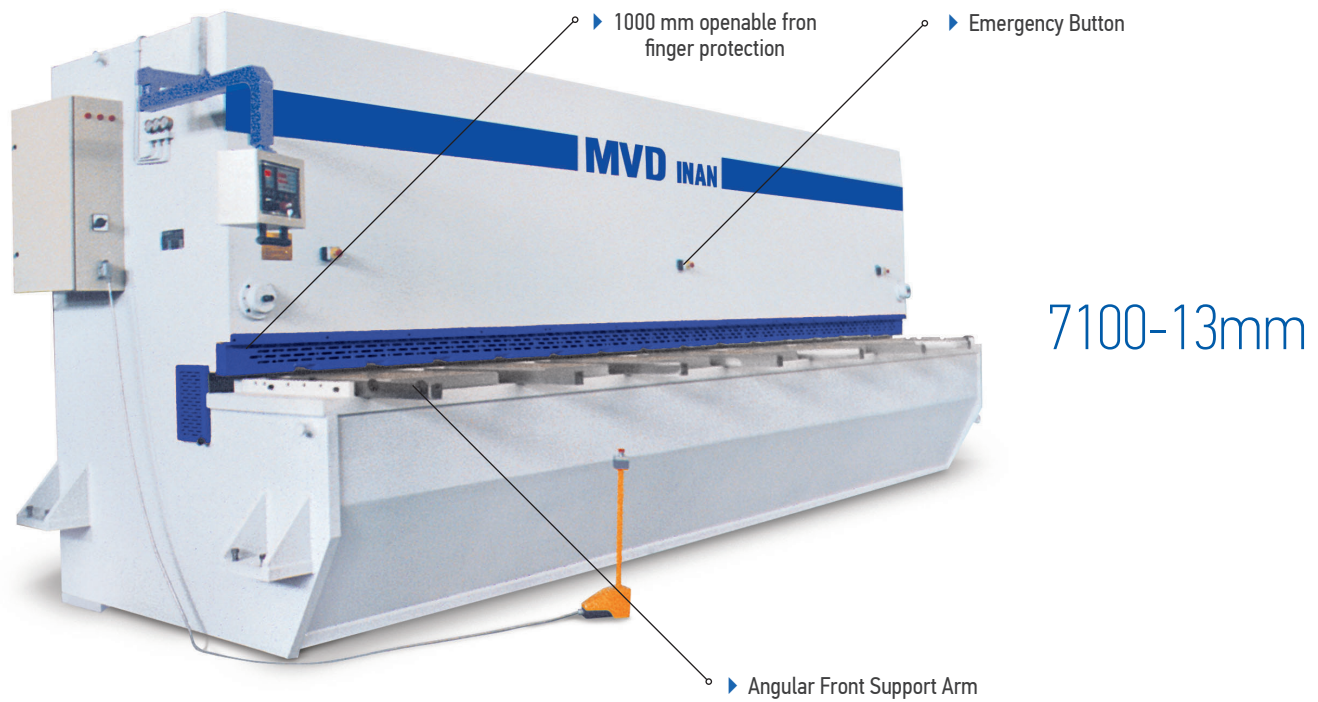



6100-20mm



6100-6mm



3100-20mm

Pneumatic System Type 1
Optional



Pneumatic System Type 2
Optional

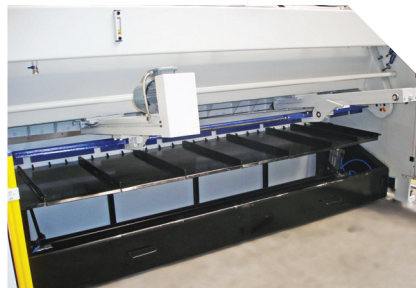

Pneumatic System Type 3
Optional



Pneumatic System Type 4
Optional

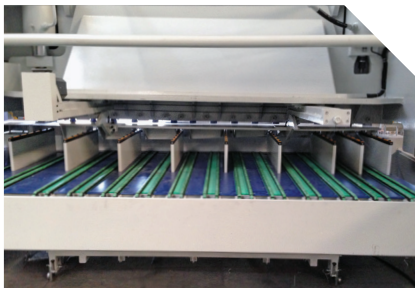

Front Arm System CNC
Optional



www.mvd.com.tr



Technical specifications are subject to change without notice.



MVD Makina Sanayi A.Ş.

ADRESS : Konya Organize Sanayi Bölgesi Evrenköy Cad.
1 Nolu Sokak No: 3 42050 Konya / Türkiye

TELEPHONE : +90 332 239 22 33 (pbx)

FAX : +90 332 239 21 21

GPS : 37° 58' 59" N, 32° 36' 34" E

WEB : www.mvd.com.tr

E-MAIL : info@mvd.com.tr

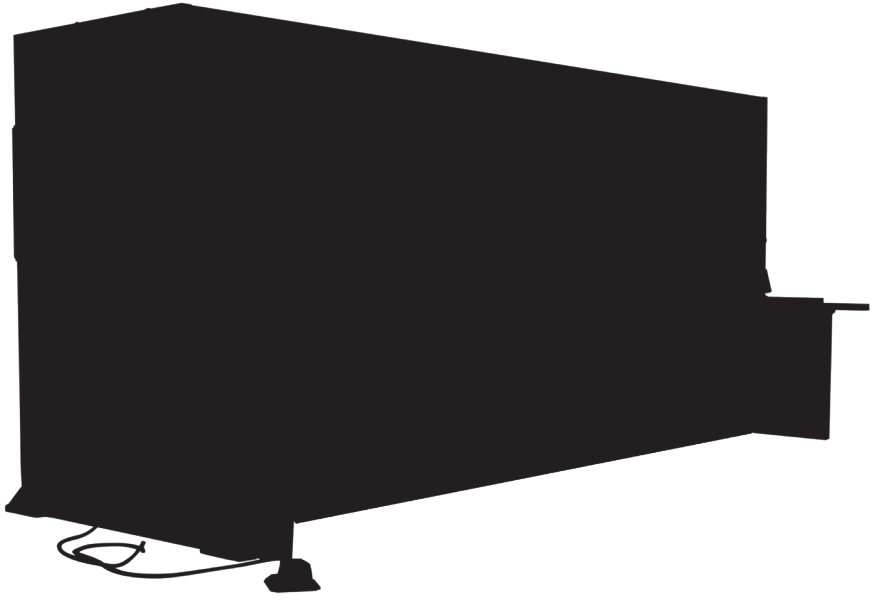

ishear

